

# Investigation of asphaltene deposition under dynamic flow conditions

Farhad Salimi<sup>1</sup> · Javad Salimi<sup>2</sup> · Mozafar Abdollahifar<sup>1</sup>

Received: 25 June 2015 / Published online: 16 March 2016  
© The Author(s) 2016. This article is published with open access at Springerlink.com

**Abstract** Asphaltene deposition is one of the most serious problems, which usually occurs in oil wells, petroleum production, oil processing, and transportation facilities. Deposition of heavy organic components, especially asphaltene, can lead to wellbore blockage and impacts well economics due to reduction in oil production. Therefore, it is necessary to pay more attention to finding some solution to overcome this problem. In this study, a pipe-loop apparatus for investigation of oil stability was employed to measure deposition thickness using a thermal method. The effects of many factors such as oil type, oil temperature, oil velocity, inhibitors, and solvents on asphaltene deposition were investigated. The results showed that the deposition increased with the increasing value of the colloidal instability index. Besides, the deposition thickness increased with the decreasing velocity of oil, but did not change with oil temperature. In addition, n-heptane could result in more deposition; however, toluene had no effect on the deposition. Branched dodecyl benzene sulfonic acid (Branched DBSA) and Linear DBSA as inhibitors decreased the rate of asphaltene deposition.

**Keywords** Asphaltene · Deposition · Dynamic flow · Pipe-loops · Inhibitors

✉ Farhad Salimi  
f.salimi@iauksh.ac.ir; farhadsalimi348@gmail.com

<sup>1</sup> Department of Chemical Engineering, Faculty of Basic Sciences, Kermanshah Branch, Islamic Azad University, Kermanshah, Iran

<sup>2</sup> Young Research and Elite Club, Kermanshah Branch, Islamic Azad University, Kermanshah, Iran

Edited by Xiu-Qin Zhu

## 1 Introduction

The formation of asphaltene deposits during petroleum production can cause several operational issues including total or partial blocking of pipelines and wellbores, changes in wettability, and damage to equipment (Islam 1994). Asphaltene deposition inside the oil reservoirs and production facilities is known as the main flow assurance problem in the oil industry.

In general, asphaltenes, which are regarded as part of the crude oil, are insoluble in normal alkanes such as pentane and heptane; however, they are soluble in aromatics like toluene and benzene. Also asphaltenes are known to have a high molecular weight and number of polar oil components (Ali and Al-Ghannam 1981; Hirschberg et al. 1984; Speight 1999).

There are many methods for identifying the stability of asphaltene in crude oil. These methods can approximately determine oils with the potential of asphaltene precipitation. Some of the older, but more popular, methods have been employed for the stability of asphaltenes, including asphaltene–resin ratio, Oliensis spot test, light scattering, measurement of particle size, colloidal instability index (CII), microscopic observations, and refractive index (RI). The latter (RI) was first introduced and used by Buckley (1999) for predicting the asphaltene precipitation onset. The results showed that the RI was independent of asphaltene content and occurred at a characteristic RI of 1.42–1.44. Another method- used to predict asphaltene deposition CII was presented by Yen et al. (2001) as  $CII = (\text{Saturates} + \text{Asphaltene}) / (\text{Aromatics} + \text{Resin})$ . They found that, if CII is less than 0.7, the oil would be stable, and asphaltene precipitation would not occur. However, if this index is higher than 0.9, the oil would be very unstable, and

thus asphaltene precipitation would occur. Finally, if it is between 0.7 and 0.9, the oil would be moderately unstable.

Asphaltene composition, structure, and stability depend on its source, type of solvent used for oil extraction, pressure, and temperature (Soorghali et al. 2014; Groenzin and Mullins 2000; Alboudwarej et al. 2002; Akbarzadeh et al. 2002). Asphaltenes as colloidal with various sizes or as individual molecules can be absorbed on solid surfaces by the virtue of their weak phenolic and carboxylic acid groups (Kokal et al. 1995). These materials can also be strongly deposited on mineral surfaces and reservoir rocks, and hence cause formation damage, and hinder oil recovery from the reservoirs (Dubey and Doe 1993; Kord et al. 2012; Zanganeh et al. 2012). Furthermore, the absorption and deposition of asphaltenes on steel surfaces would restrict oil flow in transportation pipelines (Faus et al. 1984; Mochida et al. 1988). The remediation of asphaltene is very costly, which limits the production design of many asphaltenic crude oil reserves (Hammami and Ratulowski 2007; Akbarzadeh et al. 2012; Buckley 2012).

Asphaltenes have inherent positive or negative charges, depending on the composition of crude oil. Resins have a strong desire to link asphaltenes and attract opposite charges; consequently, they make a protective layer for asphaltenes. When this protective layer is removed, asphaltene precipitation occurs. The force balance between the adsorbed resins and asphaltenes is the most important factor for crude oil instability (Mullins et al. 2007). Resins naturally act as inhibitors, group contribution of which is a factor which connects the polar (asphaltenes) and non-polar (oil bulk) media.

In the stabilization of asphaltene micelles, resins can be helpful; however, when a paraffinic solvent is added to the crude oil, the stability between resins and asphaltenes is demolished, and the amount of asphaltene monomers increases in the bulk phase. In some quantities, asphaltene concentration reaches the concentration of the onset point, and deposition occurs (Al-Sahhaf et al. 2002).

Amphiphilic molecules are among the inhibitors, often known as dispersants which are used to prevent the aggregation of the micelles of asphaltenes. The performance of inhibitors is mainly dependent on their structural and chemical characteristics. Therefore, many inhibitors have been investigated as dispersants. To prevent asphaltene precipitation, amphiphils, which are soluble in oil, can be more efficient than aromatics. There are many works that have investigated the effects of various inhibitors on the stability of asphaltenes (Hirschberg et al. 1984; Al-Sahhaf et al. 2002; González and Middea 1991; Chang and Fogler 1994; Shadman et al. 2014; Rocha Jr et al. 2006; Boukherissa et al. 2009; Ghloum et al. 2010; Ramos 2001).

Most of these methods are done under static conditions, and the onset point of asphaltene precipitation is the main

criterion for inhibitor selection. The result obtained from this section is not sufficient to choosing a suitable inhibitor. Therefore, it is important to examine the inhibitors in real flow conditions. Besides, a literature study reveals that there are only few reports on asphaltene deposition in real pipe conditions (De Boer et al. 1995; Alboudwarej 2003; Wang et al. 2004; Zougari et al. 2006; Jamialahmadi et al. 2009; Vargas et al. 2009).

In this work, we report the effects of oil, oil velocity, temperature, and inhibitors on asphaltene deposition in dynamic conditions by flow loop apparatus using a thermal approach.

### 1.1 Asphaltene deposition measurement

Direct and indirect methods are used to measure asphaltene deposition in the pipe. In the direct method, depositions are measured directly such as the weight method, with ultrasonic sensors, and caliper. In the indirect method, after the formation of a deposition layer on the internal pipe wall, convection heat transfer occurs at the interface between the flowing fluid and the deposited layer. A thermal resistance term is added to the total resistance due to heat conduction through the layer (Fig. 1). Hence, the deposit's thickness can be determined from the measurements of the relevant thermal parameters by solving the heat transfer equations. Heat transfer from the internal flowing fluid to the outside environment is described by the following equation (Chen et al. 1997):

$$\frac{1}{U_b} = \frac{1}{h_o} \frac{r_o}{r_i - \delta_d} + \frac{r_o}{k_{dep}} \ln \frac{r_i}{r_i - \delta_d} + \frac{r_o}{k_p} \ln \frac{r_o}{r_i} + \frac{1}{h_g} \quad (1)$$

where  $U_b$  is the overall heat-transfer coefficient,  $r_i$  and  $r_o$  are the inside radius and outside radius of pipe, respectively, and  $k_{dep}$ ,  $k_p$ ,  $h_o$ , and  $h_g$  are the deposit's thermal conductivity, pipe's thermal conductivity, convection coefficient of oil, and convection coefficient of the bath, respectively. The total heat-transfer rate in the test section is given by

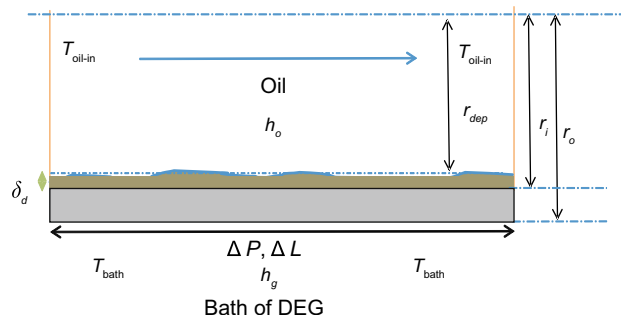

Fig. 1 The pipe cross sections and related parameters

$$Q = U_b A_b \Delta T_{lm} = m_o C_{po} (T_{o,in} - T_{o,out}) \quad (2)$$

where,  $A_b = \pi d_o L$ ; and  $m_o$ ,  $C_{po}$ , and  $\Delta T_{lm}$  are the mass flow rate, specific heat capacity, and logarithmic mean temperature difference in the heat-exchange, respectively. At the beginning of the experiment, asphaltene thickness is zero, and the heat transfer equation is as follows:

$$\frac{1}{U_{bo}} = \frac{1}{h_o} \frac{r_o}{r_i} + \frac{r_o}{k_p} \ln \frac{r_o}{r_i} + \frac{1}{h_g} \quad (3)$$

If Eq. (3) is subtracted by Eq. (1), the following equation is obtained:

$$Y = \frac{1}{U_b} - \frac{1}{U_{bo}} = \frac{1}{h_o} \frac{r_o \delta_d}{r_i (r_i - \delta_d)} + \frac{r_o}{k_{dep}} \ln \frac{r_i}{r_i - \delta_d} \quad (4)$$

The overall heat-transfer coefficient,  $U_b$  is calculated by Eq. (2), and the deposition thickness is calculated by Eq. (4).

The inside (oil) convective heat-transfer coefficient ( $h_o$ ) is obtained using the Hausen correlation (Eq. (5) (Hausen 1943):

$$N_{Nu} = 3.66 + \frac{0.19 [N_{Pe} (\frac{d_w}{L})]^{0.8}}{1 + 0.117 [N_{Pe} (\frac{d_w}{L})]^{0.467}}, \quad (5)$$

where  $N_{Pe} = N_{Re} N_{Pr}$ ,  $N_{Pr} = \mu C_{po} / k_o$ , and  $d_w$  and  $k_o$  are the diameter of the pipe open to flow and thermal conductivity of oil, respectively. Finally,  $h_o$  is obtained by Eq. (6):

$$h_o = \frac{N_{Nu} k_o}{d_w} \quad (6)$$

## 1.2 Experimental apparatus

Figure 2 shows a schematic view of the novel designed flow assurance test loop, which was used to measure the thickness of asphaltene deposition as a function of time at different conditions. The apparatus is made of a well-controlled temperature bath containing a long stainless steel tube in coil shape. The temperature of the bath was maintained constant using a heat source, controlling unit and stirrer. The long test tube was equipped with accurate pressure transducers and thermocouples at several intervals, transferring all the information into a data acquisition system. The feedstock was prepared and transferred into the feed storage, and its temperature was maintained at pre-set temperature prior to flow through the pump into the flowing loop.

In this study, the pipe test section was made of a stainless steel tube (seamless, Fitok Company) of 1 m in length and 3.74 mm in inner diameter, which was coiled

and placed inside the bath. The bulk temperatures of the oil were measured with K-type thermocouples, located in the tank and in the mixing chambers, before and after the test section. The temperature of the bath was controlled within  $\pm 0.1$  °C. The absolute pressure at the outlet of the tube was controlled with a back pressure control regulator (model BP-66). The oil flow rate was controlled by the constant rate pump. A data acquisition system was used to monitor the temperature at various points of both the bath and the tube.

## 1.3 Error analysis

The experimental error in the measurement of the mass of asphaltene deposition may result from the errors in the measurement of bulk temperature and bath temperature of the test section. The temperatures were measured with PT100 thermocouples located in the bulk of the oil flow before and after the test section. The inaccuracy in temperature measurements due to the calibration errors of the thermocouples may lead to a deviation of approximately  $\pm 0.1$  °C. The maximum error in the mass of asphaltene deposition measurements was estimated to be less than  $\pm 2.5$  % by taking into account the temperature and flow rate measurement errors.

## 1.4 Experimental materials and procedure

Two different samples of Iranian crude oil were used for investigation of asphaltene deposition. The results of SARA test for these oils are shown in Table 1. To establish a relationship between the composition and the stability behavior of the crude oils, their main constituents, namely saturates, aromatics, resins, and asphaltenes, were determined following the procedure that has already been used by Carbognani (Carbognani and Izquierdo 1989). Resins were obtained through chromatographic fractionation of the deasphalted oil. Silica was used as a packing material, and the different fractions were sequentially eluted with hexane (saturates), toluene (aromatics), and a 10 % methanol/toluene mixture (resins). The solvents were removed by distillation, and the resins were further dried under vacuum.

In order to measure the viscosity and density of oil, an Anton Paar SVM 3000 viscometer was used. The solvent used as precipitant in the viscometric method was normal heptane, and toluene, linear dodecyl benzene sulfonic acid (Linear DBSA), and branched dodecyl benzene sulfonic acid (Branched DBSA) were used as the inhibitors. Table 2 presents the chemical structure of inhibitors used. The properties of these inhibitors are presented in Table 3.

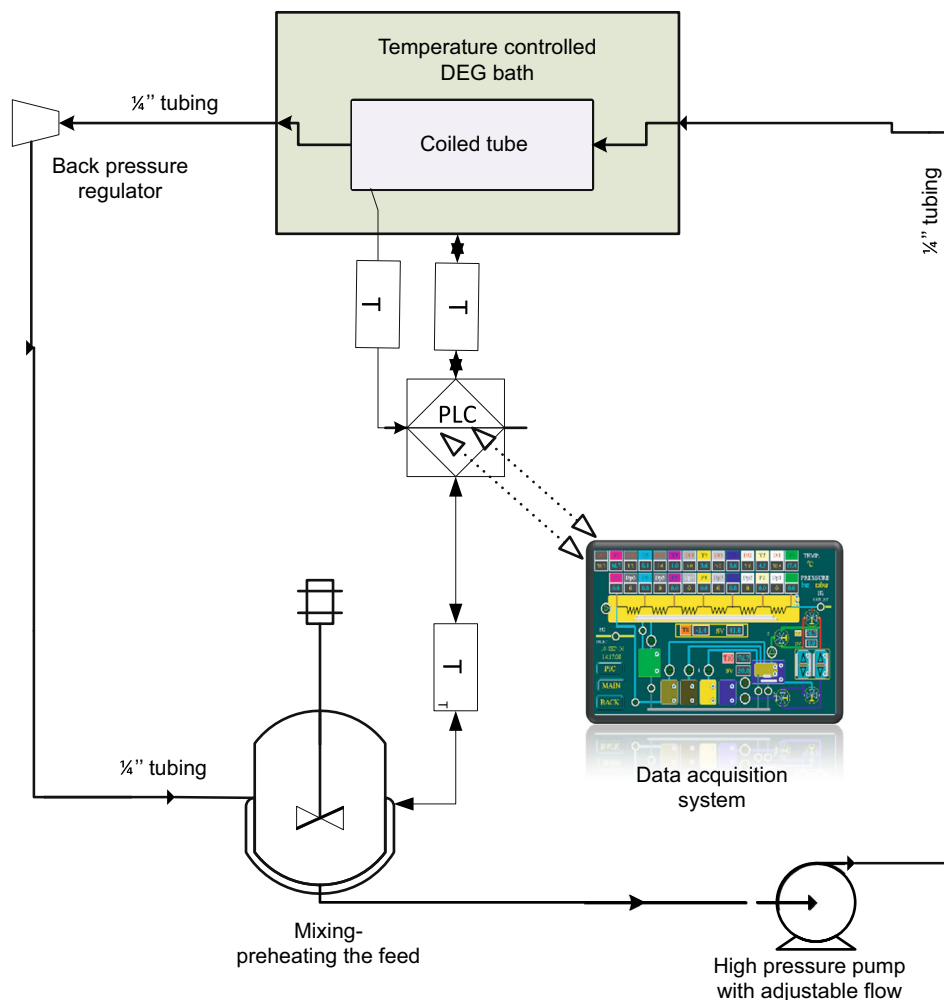

Fig. 2 Schematic of the experimental apparatus

Table 1 Analysis of SARA

	Oil 1	Oil 2
Asphaltenes	13.84	3.75
Resins	13.46	0.49
Saturates	30.31	43.67
Aromatics	42.40	52.09

The oil samples were weighed, mixed with certain amounts of inhibitor, and then put in a closed container (preheating reactor) for 0.5 h.

The experiment was conducted as follows: oil and solvent solutions were poured into the feed tank, then the stirrer was turned on, and the temperature of preheater was set to allow the feed to reach the specified temperature. Simultaneously, the temperature of the bath, which contained the pipe, was set at the test temperature. After reaching the desired temperatures of the bath and preheater, the flow rate of the pump was set and turned on. After the fluid circulated inside the pipe, the pressure of the

Table 2 Chemical structure of the inhibitors

Chemical structure	Inhibitors
<chem>Cc1ccccc1</chem>	Toluene
<chem>CC(C)CCCC(C)C1=CC=C(S(=O)(=O)O)C=C1</chem>	Linear DBSA
<chem>CCCCCCCC(C)C1=CC=C(S(=O)(=O)O)C=C1</chem>	Branched DBSA

experiment was set by a back-pressure control (BPCR) outlet valve. Next, the temperature data were gathered by data-acquisition system. Then, the correlations related to deposition measurement were applied for the collected data.

**Table 3** Properties of inhibitors used

Water, %	Molecular weight, g/gmol	Free sulfuric acid, %	Free oil, %	Acidity, mg (KOH)/g	Anionic active, %	Inhibitor
–	92.14	–	–	–	–	Toluene
0.41	322	1.35	1.89	183.9	96.4	Linear DBSA
–	321	1.8	2.2	180	96	Branched DBSA

After the experiments, 2 l of gasoline was added to the feed tank, and the pump was initiated for an hour to wash the pipes. Finally, nitrogen gas was used to dry the pipeline.

## 2 Results and discussion

The solubility of asphaltene in oil is reduced by adding normal alkanes to the oil. At this point, known as the onset, more solvent will lead the asphaltene to begin to separate from the oil. Further addition of solvent will lead to increased asphaltene precipitation.

The CII index for Oils 1 and 2 is equal to 0.79 and 0.902, respectively, and the results show that the oils are within the moderately unstable range.

According to the CII index calculated for Oil 1 and Oil 2, Oil 2 is in instability zone; however, Oil 1 is in the transition zone. So, the amount of asphaltene deposit formed in Oil 2 is expected to be greater than that in Oil 1. To investigate this issue, two experiments were carried out for both oils at the same flow rate, bulk temperature, and wall temperature. The results (see Fig. 3) showed that more asphaltene deposited from Oil 2 than from Oil 1, indicating Oil 2 was more unstable than Oil 1. Another important point was related to the time of deposition formation, occurring at the later time for Oil 1.

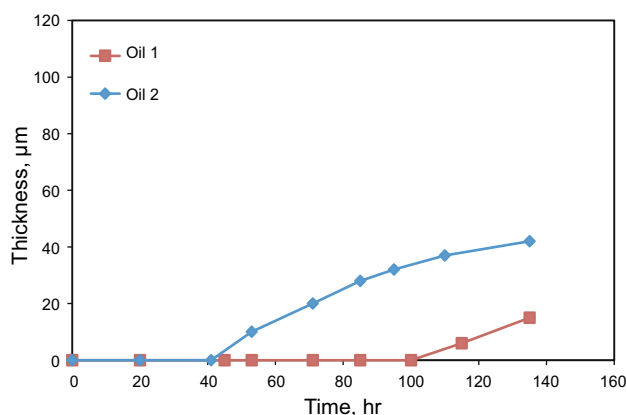

**Fig. 3** The effect of oil on the thickness of asphaltene deposit versus time in pipeline for laminar flow.  $q = 220$  cc/min,  $T_{oil} = 50$  °C,  $T_{bath} = 70$  °C

According to the CII definition, n-heptane increases CII, and toluene decreases CII. Comparison between the results of adding n-heptane (*n*-C7) to Oil 2 indicated that the thickness of asphaltene deposit increased, and the initiation time, when asphaltene deposition occurs, was decreased. Adding n-heptane to the oil led to an increased amount of asphaltene particles in the oil and increased the deposition rate of asphaltene particles. The flow rates ( $q$ ) of solvent for this test was equal to 220 cc/min, and the temperatures of oil and bath were adjusted to 50 and 70 °C, respectively. Toluene is an aromatic solvent; thus, its addition to the oil led to decreased CII index, and stabilized the oil. To study the effect of toluene, 15 % volume percent of the solvent was added to Oil 2 at the flow rate of 220 cc/min at 50 and 70 °C of oil and bath, respectively, and the obtained results are shown in Fig. 4.

Regarding the toluene solvent, as shown in Fig. 4 addition of toluene had very little effect on the amount of asphaltene deposit. There are two possible reasons for this: Addition of toluene solvent decreased the viscosity of oil and the asphaltene particles in the oil, causing them to easily move and stick to the wall. Besides, reducing the viscosity of oil led to decreased shear stress on the wall, and increased the formation of deposits on it. Although adding toluene reduced the CII index, these two factors could cause toluene to have almost no effect on the amount of asphaltene deposition.

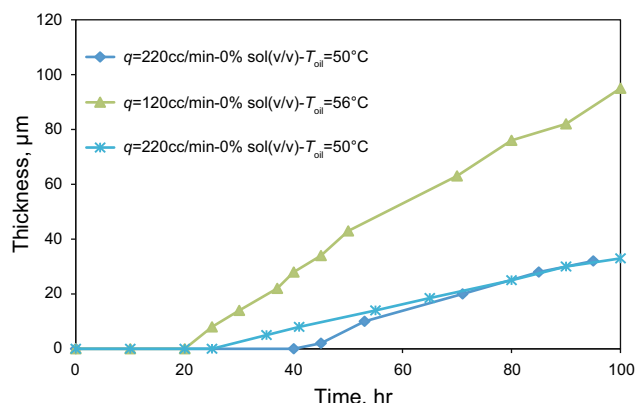

**Fig. 4** The effects of flow rate ( $q$ ) and oil temperature on the thickness of asphaltene deposit versus time for Oil 2,  $T_{bath} = 70$  °C

For calculating the laminar flow inside the pipe, the following Hagen Poiseuille equation (Sutera and Skalak 1993) was used:

$$\Delta P = \frac{32L \times \mu \times v}{d^2} \tag{7}$$

In the above equation,  $\Delta P$  is the pressure loss,  $L$ ,  $d$ , and  $v$  are the length of pipe, diameter, and dynamic viscosity, respectively

If the momentum balance is written for the pipe’s cross section, the following equation is derived:

$$\Delta P \times \pi \times r^2 = \tau \times 2\pi \times r \times L \tag{8}$$

where  $\tau$  and  $r$  are the shear stress and radius, respectively. After inserting Eq. (7) in Eq. (8), the following equation is obtained for the shear stress:

$$\tau = \frac{32\mu \times v}{d} \tag{9}$$

According to Eq. (9), the increases of velocity and viscosity led to the increase of shear stress on the wall, which could cause a reduction in the amount of asphaltene deposition.

The effect of flow rate (velocity) on asphaltene deposition was another parameter which was studied, and the results are shown in Fig. 5. As indicated, the deposition thickness was strongly dependent on this parameter. When the flow rate reduced to half, the thickness of deposition increases to about 2.5 times after 100 h. Besides, the initiation time for the deposition formation declined from about 40 h to 20 h, because the shear stress on the wall, which was directly proportional to the fluid velocity, might have caused a reduction in the erosion of the deposition layer.

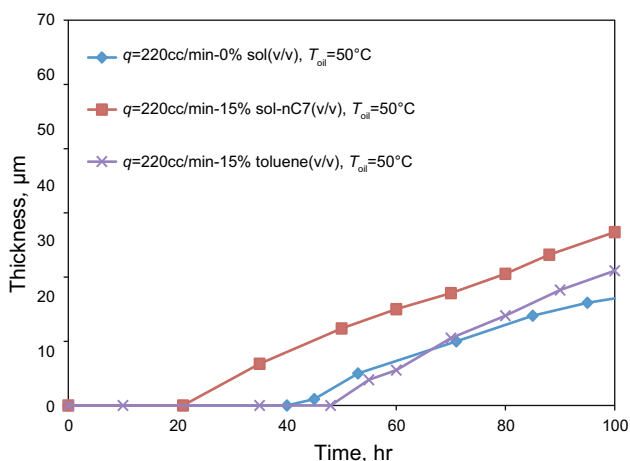

**Fig. 5** The effect of solvent on the thickness of deposition versus time for Oil 2,  $T_{\text{bath}} = 70 \text{ }^\circ\text{C}$

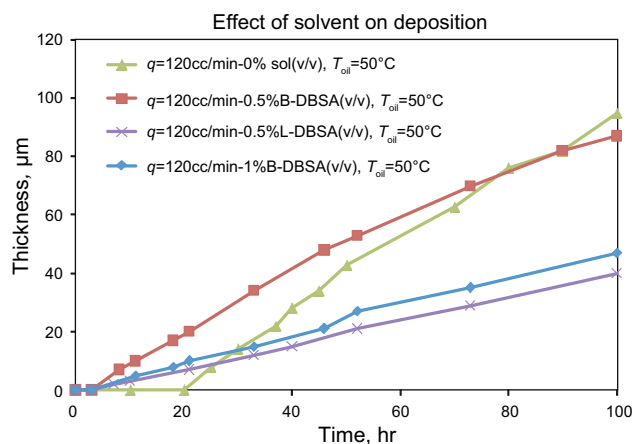

**Fig. 6** The effects of inhibitors on the deposit thickness versus time for Oil 2,  $T_{\text{bath}} = 70 \text{ }^\circ\text{C}$

Effect of oil temperature on asphaltene deposition was studied in this work. The results demonstrated that a rise of oil temperature (up to  $56 \text{ }^\circ\text{C}$ ) decreased the initiation time, when the deposition occurs; however, it had no effect on the amount of deposit after 100 h (Fig. 5).

A decreased viscosity of oil was the most important factor for reducing the initiation time of deposition to 5cp, which could decrease the shear rate on the inner pipe surface, and increase the deposit.

Figure 6 shows the effects of type and amount of inhibitors on asphaltene deposition formed on the pipe surface. It can be seen that the presence of inhibitors can decrease the initiation time, when the deposition occurs, and accelerate asphaltene deposition. However, an important point, which was found while adding inhibitors to the crude oil, was the reduction of slope related to the formation of asphaltene deposition or deposition rate on the inner pipe surface. Comparison of different inhibitors indicated that L-DBSA had greater influence on decreasing of deposition rate than B-DBSA. It can be explained that the existence of branches on B-DBSA could lead to the reduced effect of inhibitors in comparison to the inhibitors without branches on its structure. Nevertheless, the deposition rate decreased with increasing concentration of B-DBSA.

### 3 Conclusions

In this study, asphaltene deposition stability was successfully investigated under dynamic flow conditions. The effects of many factors such as oil, temperature, solvent, inhibitor, and velocity on the rate of deposition inside the pipe were studied. It was found that the presence of oil with more CII led to the increased asphaltene deposition. The deposition thickness increased with the decreasing velocity



but did not with oil temperature. More deposition occurred by adding n-heptane; however, toluene had no effect on the deposition. Data revealed that addition of chemical inhibitors had a significant effect on the asphaltene' particle size, prevented further growth of the asphaltene particles, and delayed the onset of asphaltene deposition.

**Acknowledgments** We would like to thank the supports from Islamic Azad University, Kermanshah Branch.

**Open Access** This article is distributed under the terms of the Creative Commons Attribution 4.0 International License (<http://creativecommons.org/licenses/by/4.0/>), which permits unrestricted use, distribution, and reproduction in any medium, provided you give appropriate credit to the original author(s) and the source, provide a link to the Creative Commons license, and indicate if changes were made.

## References

- Alboudwarej H, Beck J, Svrcek WY, et al. Sensitivity of asphaltene properties to separation techniques. *Energy Fuels*. 2002;16:462–9.
- Alboudwarej H. *Chemical and Petroleum Engineering*. Calgary: University of Calgary; 2003.
- Ali LH, Al-Ghannam KA. Investigations into asphaltene in heavy crude oils. I. Effect of temperature on precipitation by alkane solvents. *Fuel*. 1981;6:1043–6.
- Al-Sahhaf TA, Fahim MA, Elkilani AS. Retardation of asphaltene precipitation by addition of toluene, resins, deasphalted oil and surfactants. *Fluid Phase Equilib*. 2002;194:1045–57.
- Akbarzadeh K, Ayatollahi S, Nasrifar K, et al. Equations lead to asphaltene deposition prediction. *Oil Gas J*. 2002;100(44):51.
- Akbarzadeh K, Dmitry E, Ratulowski J, et al. Asphaltene deposition measurement and modeling for flow assurance of tubings and flow lines. *Energy Fuels*. 2012;26:495–510.
- Boukherissa M, Mutelet F, Modarressi A, et al. Ionic liquids as dispersants of petroleum asphaltenes. *Energy Fuels*. 2009;23:2557–64.
- Buckley JS. Predicting the onset of asphaltene precipitation from refractive index measurements. *Energy Fuels*. 1999;13:328–32.
- Buckley JS. Asphaltene deposition. *Energy Fuels*. 2012;26:4086–90.
- Carbognani L, Izquierdo A. Preparative and automated compound class separation of Venezuelan vacuum residua by high-performance liquid chromatography. *J. Chromatogr. A*. 1989;484:399–408.
- Chang CL, Fogler HS. Stabilization of asphaltenes in aliphatic solvents using Alkylbenzene-derived amphiphiles. 2. Study of the asphaltene-amphiphile interactions and structures using Fourier transform infrared spectroscopy and small-angle X-ray scattering techniques. *Langmuir*. 1994;10:1749–57.
- Chen XT, Butler T, Volk M, et al. Techniques for measuring wax thickness during single and multiphase flow. In: SPE annual technical conference and exhibition. Society of Petroleum Engineers. Accessed Jan 1997.
- De Boer R, Leerlooyer K, Eigner MRP, et al. Screening of crude oils for asphalt precipitation: theory, practice, and the selection of inhibitors. *SPE Prod. Facil*. 1995;10:55–61.
- Dubey ST, Doe PH. Base number and wetting properties of crude oils. *SPE Reserv. Eng*. 1993;8:195–200.
- Faus FM, Grange P, Delmon B. Influence of asphaltene deposition on catalytic activity of cobalt molybdenum on alumina catalysts. *Appl. Catal*. 1984;11:281–93.
- Ghloum EF, Al-Qahtani M, Al-Rashid A. Effect of inhibitors on asphaltene precipitation for Marrat Kuwaiti reservoirs. *J. Pet. Sci. Eng*. 2010;70:99–106.
- González G, Middea A. Peptization of asphaltene by various oil soluble amphiphiles. *Colloids Surf*. 1991;52:207–17.
- Groenzin H, Mullins OC. Molecular size and structure of asphaltenes from various sources. *Energy Fuels*. 2000;14:677–84.
- Hammami A, Ratulowski J. Precipitation and deposition of asphaltenes in production systems: a flow assurance overview. In: Mullins OC, Sheu EY, Hammami A, Marshall AG, editors. *Asphaltenes, heavy oils, and petroleomics*. Berlin: Springer; 2007. p. 617–60.
- Hausen H. Darstellung des Wärmeüberganges in Rohren durch verallgemeinerte Potenzbeziehungen. *Z. VDI Beih. Verfahrenstech*. 1943;4:91–8.
- Hirschberg A, DeJong LNJ, Schipper BA, et al. Influence of temperature and pressure on asphaltene flocculation. *Soc. Pet. Eng*. 1984;24:283–93.
- Islam MR. Role of asphaltenes on oil recovery and mathematical modeling of asphaltene properties. *Dev. Pet. Sci*. 1994;40:249–98.
- Jamialahmadi M, Soltani B, Müller-Steinhagen H, et al. Measurement and prediction of the rate of deposition of flocculated asphaltene particles from oil. *Int. J. Heat Mass Transf*. 2009;52:4624–34.
- Rocha LC Jr, Ferreira MS, Da Silva Ramos AC. Inhibition of asphaltene precipitation in Brazilian crude oils using new oil soluble amphiphiles. *J. Pet. Sci. Eng*. 2006;51:26–36.
- Kokal S, Tang T, Schramm L, et al. Electrokinetic and adsorption properties of asphaltenes. *Colloids Surf. A*. 1995;94:253–65.
- Kord S, Miri R, Ayatollahi S, et al. Asphaltene deposition in carbonate rocks: experimental investigation and numerical simulation. *Energy Fuels*. 2012;26:6186–99.
- Mochida I, Zhao XZ, Sakanishi K. Catalyst deactivation during the hydrotreatment of asphaltene in an Australian brown coal liquid. *Fuel*. 1988;67:1101–5.
- Mullins OC, Sheu YE, Hammami A, et al. *Asphaltenes, heavy oils, and petroleomics*. Berlin: Springer Sci. & Business Media; 2007.
- Ramos ACS. *Agregação em solventes aromaticos, desenvolvimento de aditivos e estabilização de emulsões*. Doctoral dissertation, Universidade Estadual de Campinas (UNICAMP), 2001.
- Shadman MM, Dehghanizadeh M, Saeedi Dehaghani AH, et al. An investigation of the effect of aromatic, anionic and nonionic inhibitors on the onset of asphaltene precipitation. *J. Oil Gas Petrochem. Technol*. 2014;1:17–28.
- Soorghali F, Zolghadr A, Ayatollahi S. Effect of resins on asphaltene deposition and the changes of surface properties at different pressures: a microstructure study. *Energy Fuels*. 2014;28:2415–21.
- Speight JG. *The chemistry and technology of petroleum*. New York: Marcel Dekker; 1999.
- Sutera SP, Skalak R. The history of Poiseuille's law. *Annu. Rev. Fluid Mech*. 1993;25:1–20.
- Wang J, Buckley JS, Creek JL. Asphaltene deposition on metallic surfaces. *J. Dispers. Sci Technol*. 2004;25:287–98.
- Vargas FM, Gonzalez DL, Hirasaki GJ, et al. Modeling asphaltene phase behavior in crude oil systems using the perturbed chain form of the statistical associating fluid theory (PC-SAFT) equation of state. *Energy Fuels*. 2009;23:1140–6.
- Yen A, Yin YR, Asomaning S. Evaluating asphaltene inhibitors: Laboratory tests and field studies. In: SPE international symposium on oilfield chemistry. Society of Petroleum Engineers. Accessed Jan 2001.
- Zanganeh P, Ayatollahi S, Alamdari A, et al. Asphaltene deposition during CO<sub>2</sub> injection and pressure depletion: a visual study. *Energy Fuels*. 2012;26:1412–9.
- Zougari M, Jacobs S, Hammami A, et al. Novel organic solid deposition and control device for live oils: design and applications. *Energy Fuels*. 2006;20:1656–63.